

No. of Pages:02

Roll No: .....

A-10

B. Tech. CE/ME/TE I Semester Examinations (Dec 2025)  
Engineering Graphics & Design (BT-ME-104A)

Time- 3hrs  
Max.Marks-60

*Attempt 5 questions in all, selecting one question from each unit and Question 1 is compulsory. Each Question carries 12 marks. Assume any missing data.*

Q.1

Marks (2x6)

- (a) Explain any two types of Lines used in Engineering Drawing.
- (b) A circular lamina of diameter 50 mm is placed a point on HP in such a way such it is parallel to VP and perpendicular to HP. Draw its projections.
- (c) What do you understand by Development of surfaces. Where are these used?
- (d) What is isometric scale? Discuss with help of diagram.
- (e) Define a section and sectional view?
- (f) Define Diagonal and Vernier Scale.

**UNIT-I**

Q.2(a) A point A is 20 mm above the HP and 50 mm in front of the VP. Another point B is 40 mm below the HP and 15mm behind the VP. The distance between the projectors of the points, measured parallel to xy, is 75mm. Draw the projections of the points. Draw lines joining their Front Views and Top Views. (8)

Q.2(b) Mark the projections of the following points on a common reference line: a) A, 20 mm above HP and 30 mm in front of VP. b) B, 20 mm below HP and 30 mm in front of VP. (4)

Q.3 A line AB measuring 70 mm has its end A 15 mm in front of VP and 20 mm above HP and the other end B 60 mm in front of VP and 50 mm above HP. Draw the projections of the line and find the inclinations of the line with both the reference planes of projection. (12)

**UNIT-II**

Q.4 A circular lamina of 50 mm diameter rests on HP such that one of its diameters is inclined at  $30^{\circ}$  to VP and  $45^{\circ}$  to HP. Draw its top and front views in this position. (12)

Q.5 A hexagonal prism of base side 30 mm and axis length 60 mm rests on the HP on one of its base edges with its axis inclined at  $60^{\circ}$  to the HP and parallel to the VP. Draw its top and front views. (12)

**UNIT-III**

Q.6 A hexagonal pyramid side of base 30 mm and altitude 70 mm rests with its base on HP and with a side of base parallel to VP. It is cut by a plane inclined at  $35^{\circ}$  to HP, (12)

perpendicular to VP and bisecting the axis. Draw its top sectional view, front view and true shape of the section.

Q.7 A cylinder with a base diameter of 50 mm and a height of 70 mm rests on its base on the ground. A cutting plane inclined at  $40^\circ$  to H.P. and meeting the axis 35 mm from the base. Draw the development of the lower portion of the cylinder. (12)

**UNIT-IV**

Q.8 Draw isometric projection of a hexagonal prism of side of base 40 mm and height 60 mm with a right circular cone of base 40 mm as diameter and height 60 mm, resting on its top such that the axes of both solids are collinear. (12)

Q.9 Draw the front, top and side view of the given figure. (12)

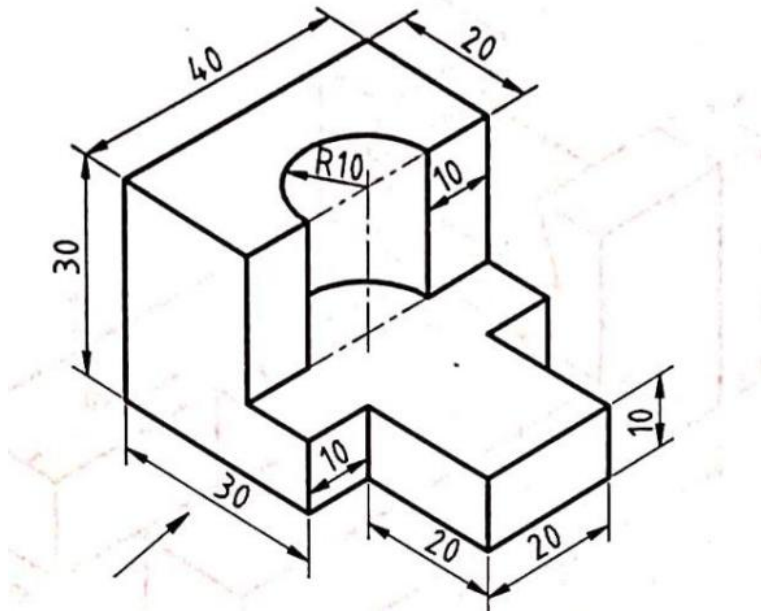

-----

No. of Pages: 02

Roll No: .....

**B-1105**

**MCA II Semester Examinations (Dec 2025)  
Design Thinking & Innovation(BT-ME-112A)**

**Time- 3hrs**

**Max.Marks-60**

*Attempt 5 questions in all, selecting one question from each unit and Question 1 is compulsory. Each Question carries 12 marks.*

	<b>Marks</b>
Q.1	
(a) What is the origin and purpose of Design Thinking?	2x6=12
(b) Differentiate between creativity and innovation.	
(c) State the purpose of an empathy map.	
(d) What is lateral thinking?	
(e) Define Personas.	
(f) What do you mean by testing of prototype?	

**UNIT-I**

Q.2(a) Explain Design Thinking process. Discuss its origin and purpose.	6
Q.2(b) Differentiate between creativity and innovation. Explain their role and significance in organizational growth	6
Q.3(a) What is the Innovation Life Cycle? Illustrate its stages with suitable examples.	6
Q.3(b) Discuss the importance of empathy in the Design Thinking process. How does it influence the Define and Ideate stages?	6

**UNIT-II**

Q.4(a) What is an Empathy Map? Discuss its purpose and describe the different components.	6
Q.4(b) Explain the various methods of define phase	6
Q.5(a) Describe the various methods of Empathize maps	6
Q.5(b) Define trend analysis in the context of empathizing with users.	6

**UNIT-III**

Q.6(a) Explain the major challenges in idea generation. How can designers overcome these challenges?	6
Q.6(b) Discuss the importance of visualizing and empathizing before ideating.	6
Q.7(a) Explain any four ideation tools with suitable examples.	6
Q.7(b) What is SCAMPER? Explain how this technique can help in improving or transforming an existing idea.	6

#### UNIT-IV

- |        |   |   |
|--------|---|---|
| Q.8(a) | Define a prototype. Discuss its concept and explain why it is essential in design thinking. | 6 |
| Q.8(b) | Describe various types of prototypes and their purpose in design thinking.                  | 6 |
| Q.9(a) | Discuss the unique characteristics and challenges of prototyping for physical products.     | 6 |
| Q.9(b) | Explain the various steps involved in testing prototypes with users?                        | 6 |

-----

No. of Pages: 02

Roll No: .....

C-111

B. Tech. Mechanical Engineering III Semester Examinations (Dec 2025)

Theory of Machines (BT-ME-201A)

Time- 3hrs

Max.Marks-60

*Attempt 5 questions in all, selecting one question from each unit and Question 1 is compulsory. Each Question carries 12 marks.*

Q.1	Define following terms:	Marks
(a)	Kinematic link, Kinematic pair & Kinematic Chain	2
(b)	Degree of freedom of a Mechanism	2
(c)	Lower pair & higher pair	2
(d)	Pitch circle	2
(e)	Circular Pitch	2
(f)	Module	2

#### UNIT-I

Q.2(a)		5
--------	--	---

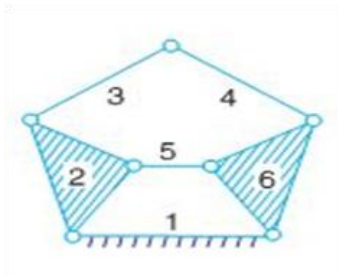

Determine the mobility (degree of freedom) of the mechanism shown in figure.

Q.2(b)	What do you understand by Inversion of a chain? Describe the Mechanism obtained by Inversion of four bar chain.	7
Q.3	In a four-bar chain ABCD, AD is fixed and is 150 mm long. The crank AB is 40 mm long and rotates at 120 r.p.m. clockwise, while the link CD = 80 mm oscillates about D. BC and AD are of equal length. Find the angular velocity of link CD when angle BAD = 60°.	12

#### UNIT-II

Q.4	What is Corolis acceleration component? In which cases does it occur? How is it determined?	12
Q.5	Draw the profile of a cam operating a knife edge follower having a lift of 30 mm. The cam raises the follower with SHM for 150° of the rotation followed by a period of dwell for 60°. The follower descends for the next 100° rotation of cam with uniform velocity, again followed by a dwell period. The cam rotates at a uniform velocity of 120 rpm and has a least radius of 20 mm.	12

#### UNIT-III

Q.6(a)	Define 'inertia force' and 'inertia torque'.	5
--------	--	---

- Q.6(b) How are velocity and acceleration of the slider of a single slider crank chain determined analytically? 7
- Q.7 Four masses  $m_1, m_2, m_3$  and  $m_4$  are 200 kg, 300 kg, 240 kg and 260 kg respectively. 12  
The corresponding radii of rotation are 0.2 m, 0.15 m, 0.25 m and 0.3 m respectively and the angles between successive masses are  $45^\circ, 75^\circ$  and  $135^\circ$ . Find the position and magnitude of the balance mass required, if its radius of rotation is 0.2 m.

#### UNIT-IV

- Q.8(a) Explain the phenomena of 'slip' and 'creep' in a belt drive. 4
- Q.8(b) For a flat belt, prove that 8  
 $T_1/T_2 = e^{\mu\theta}$  where  
 $T_1$  = Tension in the tight side of the belt,  
 $T_2$  = Tension in the slack side of the belt,  
 $\mu$  = Coefficient of friction between the belt and the pulley, and  
 $\theta$  = Angle of contact between the belt and the pulley (in radians.)
- Q.9(a) Differentiate between cycloidal teeth and involute teeth profile. 4
- Q.9(b) An epicyclic train of gears is arranged as shown in Fig. How many revolutions does 8  
the arm, to which the pinions B and C are attached, make:  
1. when A makes one revolution clockwise and D makes half a revolution anticlockwise, and  
2. when A makes one revolution clockwise and D is stationary?  
The number of teeth on the gears A and D are 40 and 90 respectively.

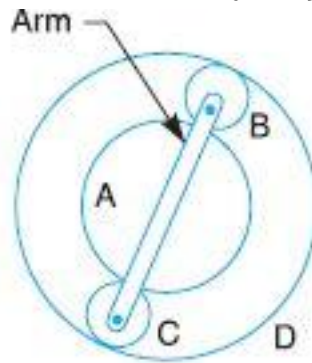

-----

No. of Pages: 02

Roll No: .....

C-112

B. Tech. Mechanical Engineering III Semester Examinations (Dec 2025)  
Mechanics of Solids-I (BT-ME-203A)

Time- 3hrs  
Max.Marks-60

Attempt 5 questions in all, selecting one question from each unit and Question 1 is compulsory. Each Question carries 12 marks.

Q.1	Marks
(a) Define Poisson's ratio	2
(b) Define principal stress.	2
(c) Write types of loads	2
(d) Define neutral Axis and point of contra flexure.	2
(e) Define torque and torsion.	2
(f) Define strut.	2

UNIT-I

Q.2(a) Derive expression of elongation of a bar of uniform section subjected to its own weight.	6
Q.2(b) Find young's modulus of a brass rod of diameter 30 mm and of length 250 mm subjected to a tensile load of 60 kN when extension of the rod is equal to 0.3 mm,	6
Q.3(a) At a point within the body subjected to two mutually perpendicular directions, the stresses are $100 \text{ N/mm}^2$ tensile and $50 \text{ N/mm}^2$ tensile. Each of the above stresses is accompanied by a shear stress of $60 \text{ N/mm}^2$ . Determine the normal stress, shear stress and resultant stress on an oblique plane inclined to $45^\circ$ with the axis of minor tensile stress.	8
Q.3(b) Write the significance of principal stresses and strains. Also, give importance of principal plane.	4

UNIT-II

Q.4(a) Write sign convention for Shear force and Bending Moment.	4
Q.4(b) Draw a S.F. And B.M diagrams for a beam which is loaded as shown in figure 1. Determine the points of contra flexure within span AB.	8

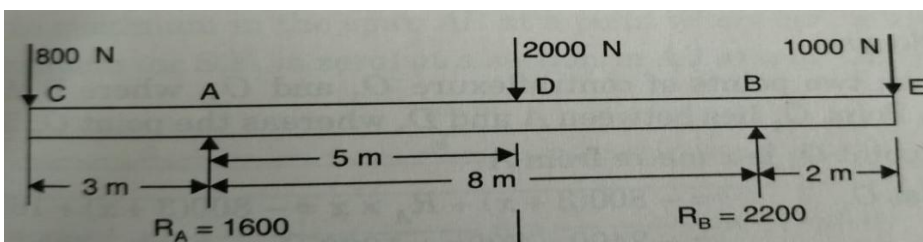

Figure 1.

- Q.5(a) Write assumptions used to derive bending equation. 4
- Q.5(b) A rectangular beam of 200mm deep and 300 mm wide is simply supported over a span of 8 m. Find U.D.L per meter the beam carry, if bending stress not to exceed 120 N/mm<sup>2</sup> 8

### UNIT-III

- Q.6(a) Derive an expression for maximum power transmitted by a hollow shaft. 6
- Q.6(b) Determine the diameter of a solid shaft which will transmit 300 kW power at 2500 r. p.m. If the maximum permitted shear stress is 30 MPa and angle of twist should not be more than 1° in a shaft length of 2m. Take  $G = 1.0 \times 10^5$  N/mm<sup>2</sup> 6
- Q.7(a) Show that for a rectangular section of maximum shear stress is 1.5 times that of average stress. 6
- Q.7(b) A circular beam of 100 mm diameter is subjected to a shear force of 10 kN. Calculate average shear stress and maximum shear stress. 6

### UNIT-IV

- Q.8(a) Derive an expression for crippling load when one end of the column is fixed other is hinged. 6
- Q.8(b) A hollow cylindrical C.I. column is 4m long with both ends fixed. Determine the minimum diameter of column if it has to carry a safe load of 300 kN with a F.O.S. equal to 5, Assume internal diameter of column is 0.8 times the external diameter of column. Take yield stress, =550 N/mm<sup>2</sup> and  $\alpha = \frac{1}{1600}$  in Rankine's formula. 6
- Q.9(a) Derive an expression for the slope and deflection of a simply supported beam subjected to a couple at mid span. Apply any method. 8
- Q.9(b) A beam of length 4m is simply supported at its ends and carries a point load of 7kN at its centre. Find the deflection at its centre. The beam is 140 mm wide and 240 mm deep. Given  $E = 6 \times 10^3$  N/mm<sup>2</sup> 4

-----

No. of Pages: 02

Roll No: .....

C-113

B. Tech. Mechanical Engineering III Semester Examinations (Dec 2025)

Thermodynamics (BT-ME-205A)

Time- 3hrs

Max.Marks-60

Attempt 5 questions in all, selecting one question from each unit and Question 1 is compulsory. Each Question carries 12 marks.

Q.1	Marks
(a) Prove that for an isolated system, there is no change in internal energy.	2
(b) What is thermal energy reservoir?	2
(c) What are the causes of irreversibility?	2
(d) Discuss the critical condition of steam.	2
(e) How does the Vander Waal's equation differ from the ideal gas equation of state?	2
(f) What do you understand by phase equilibrium?	2

**UNIT-I**

Q.2(a) Explain how the automobile radiator can be analyzed as a closed system or as an open system?	5
Q.2(b) 1.5 Kg of air gas at a pressure of 8 bar and 20°C occupies the volume of 0.15 m <sup>3</sup> . It expands adiabatically to a pressure of 0.9 bar and volume 0.73 m <sup>3</sup> . Determine i) Values of two specific heats C <sub>p</sub> and C <sub>v</sub> ii) Specific internal energy iii) The work done during the process.	7
Q.3(a) Distinguish between Macroscopic energy and Microscopic energy.	5
Q.3(b) Determine the work transfer and heat transfer a system in which a perfect gas having molecular weight of 16Kg/ Kmol is compressed from 101.3KPa. 20°C to a pressure of 600 KPa. Following the law $PV^{1.3} = \text{constant}$ . Take specific heat at constant pressure of gas as 1.7 kJ/kg -K	7

**UNIT-II**

Q.4(a) Describe the perpetual motion machine of first kind [PMM1]?	4
Q.4(b) A gas of mass 1.5 kg undergoes a quasi-static expansion which follows a relationship $p = a + bV$ , where a and b are constants. The initial and final pressures are 1000 kPa and 200 kPa respectively and the corresponding volumes are 0.20 m <sup>3</sup> and 1.20 m <sup>3</sup> . The specific internal energy of the gas is given by the relation $u = 1.5 pv - 85 \text{ kJ/kg}$ Where p is the kPa and v is in m <sup>3</sup> /kg. Calculate the net heat transfer and the maximum internal energy of the gas attained during expansion.	8
Q.5(a) Explain the kelvin Planck's second law statement.	4

- Q.5(b) A reversible heat pump is used to maintain a temperature of  $0^{\circ}\text{C}$  in a refrigerator when it rejects the heat to the surroundings at  $25^{\circ}\text{C}$ . If the heat removal rate from the refrigerator is  $1440\text{kJ/min}$ , determine the COP of the machine and the work input required. (ii) If the required input to run the pump is developed by a reversible engine which receives heat at  $380^{\circ}\text{C}$  and rejects heat to the atmosphere and then determines the overall COP of the system. 8

### UNIT-III

- Q.6(a) Explain the throttling process. 4
- Q.6(b)  $5\text{ m}^3$  of air at 2 bar,  $27^{\circ}\text{C}$  is compressed up to 6 bar pressure following  $Pv^{1.3}=\text{constant}$ . It is subsequently expanded adiabatically to 2 bar. Considering the two processes to be reversible, determine the network, net heat transfer and change in entropy. Also plot the processes on T-s and p-V diagrams. 8
- Q.7(a) Define available energy and unavailable energy. 6
- Q.7(b) 2 kg of air at 500 kPa  $80^{\circ}\text{C}$  expands adiabatically in a closed system until its volume is doubled and its temperature become equal to that the surrounding at 100 kPa and  $5^{\circ}\text{C}$ . Calculate maximum work, change in availability and the irreversibility. 6

### UNIT-IV

- Q.8(a) Define specific steam consumption, specific heat rate and work ratio. 5
- Q.8(b) A vessel of volume  $0.04\text{ m}^3$  contains a mixture of saturated water and saturated steam at a temperature of  $250^{\circ}\text{C}$ . The mass of the liquid present is 9 kg. Evaluate the pressure, the mass, the specific volume, the enthalpy, and entropy, and the internal energy of the mixture. 7
- Q.9 Derive the Maxwell relations and explain their importance in thermodynamics. 12

- - -

**No. of Pages: 02**

**Roll No: .....**

**C-114**

**B. Tech. Mechanical Engineering III Semester Examinations (Dec 2025)  
Manufacturing Science (BT-ME-207A)**

**Time- 3hrs  
Max.Marks-60**

**Attempt 5 questions in all, selecting one question from each unit and Question 1 is compulsory. Each Question carries 12 marks.**

	<b>Marks</b>
Q.1	
(a) What is the purpose of draft allowance?	2
(b) What is meant by metal forming?	2
(c) What is the function of flux in welding?	2
(d) What is meant by plastic deformation in solid-state welding?	2
(e) Name any two methods of atomization.	2
(f) State any one driving force for sintering.	2
<b>UNIT-I</b>	
Q.2(a) Describe the various types of pattern allowances. Why are these allowances necessary in casting?	6
Q.2(b) Explain the components of a gating system. Describe the design considerations for an efficient gating system.	6
Q.3(a) Describe the investment casting process. Explain its steps, advantages, and applications.	6
Q.3(b) Explain the permanent mold casting process. Discuss its working principle, advantages and applications.	6
<b>UNIT-II</b>	
Q.4(a) Describe the rolling process. Explain the types of rolling mills, common rolling defects.	6
Q.4(b) Explain the extrusion process. Discuss different types of extrusion and the common defects that occur during extrusion.	6
Q.5(a) Describe blanking and punching operations. Differentiate between the two with neat sketches and mention their applications.	6
Q.5(b) Explain stretching and embossing operations. Discuss how these processes are performed and their typical applications.	6
<b>UNIT-III</b>	
Q.6(a) Describe the thermit welding process. Explain its working principle, equipment used, and applications.	6
Q.6(b) Explain resistance welding. Describe the principle and working of spot welding or seam welding.	6

- Q.7(a) Describe the friction welding process. Explain its working principle, stages of welding, and major applications. 6
- Q.7(b) What are common welding defects? Explain any four welding defects along with their causes and remedies. 6

**UNIT-IV**

- Q.8(a) Describe in detail the different particle size measurement techniques and explain how particle shape, size distribution, and interparticle friction influence the processing of metal powders. 6
- Q.8(b) Explain slurry techniques used for shaping in powder metallurgy. 6
- Q.9(a) Write detailed notes on Hot Isostatic Pressing (HIP) and Spark Plasma Sintering (SPS). Explain the working principles, process parameters, and advantages of each method. 6
- Q.9(b) Describe the importance of powder characteristics such as particle size, shape, and surface area. 6

--- ---- ----

No. of Pages: 02

Roll No: .....

C-116

B. Tech. Mechanical Engineering III Semester Examinations (Dec 2025)

Electrical Vehicle Engineering (BT-ME-251A)

Time- 3hrs

Max.Marks-60

*Attempt 5 questions in all, selecting one question from each unit and Question 1 is compulsory. Each Question carries 12 marks.*

Q.1	Marks
(a) Explain the concept of rolling resistance in the context of vehicle dynamics.	2
(b) What is aerodynamic drag and how does it affect the performance of electric vehicles?	2
(c) What factors influence the energy density of a battery, and why is it important for Electric Vehicle (EV) performance?	2
(d) What is the role of a capacitor in a motor controller circuit?	2
(e) How do rebates and tax incentives promote the adoption of electric vehicles (EVs)?	2
(f) What is wireless charging for electric vehicles, and how does it work?	2

#### UNIT-I

Q.2(a) Compare the architectures of Battery Electric Vehicles (BEVs), Hybrid Electric Vehicles (HEVs), and Fuel Cell Electric Vehicles (FCEVs), providing their advantages and limitations.	6
Q.2(b) How is power required for rolling motion calculated in real-world electric vehicle designs?	6
Q.3(a) How do factors like tractive force, air resistance, and rolling resistance influence these calculations?	7
Q.3(b) Discuss the challenges and benefits of solar-powered vehicles, and compare their efficiency to conventional EVs powered by batteries alone.	5

#### UNIT-II

Q.4(a) Discuss the role of the cathode, anode, electrolyte, separator, and their influence on the battery's performance, including factors such as energy storage capacity and charging/discharging behavior	6
Q.4(b) Discuss the impact of maximum acceleration, load conditions, and type of motor (DC, AC, or reluctance) on overall vehicle performance.	6
Q.5(a) Describe the charging process for an electric vehicle and the different charging levels.	7
Q.5(b) Evaluate the challenges and benefits of using Lithium-Ion batteries in electric vehicles.	5

### UNIT-III

- Q.6(a) Describe the various types of controllers used in Electric Vehicles (EVs), including step-down DC controllers, step-up/down DC controllers, and AC controllers. 7
- Q.6(b) Explain the concept of energy efficiency in electric vehicles. How do these impact the overall energy consumption of EVs? 5
- Q.7(a) Evaluate the emissions profile of different types of vehicles, including diesel, diesel-electric hybrids, gasoline, CNG, and hydrogen fuel cell vehicles. 7
- Q.7(b) Analyze the role of emission norms and regulations in reducing the environmental impact of vehicles. 5

### UNIT-IV

- Q.8(a) Discuss how various national and regional policies are attempting to overcome these challenges. 6
- Q.8(b) What are the potential advantages and challenges of these technologies in terms of convenience, infrastructure requirements, and vehicle adoption? 6
- Q.9(a) Analyze the developments in electric vehicle battery technology, focusing on improvements in range, energy density, and cost reduction. 7
- Q.9(b) How are manufacturers exploring new shapes, materials, and technologies to enhance vehicle efficiency, performance, and sustainability? 5

--- ----

No. of Pages: 02

Roll No: .....

C-117

B. Tech. Mechanical Engineering III Semester Examinations (Dec 2025)  
Mobile & Field Robots (BT-ME-253A)

Time- 3hrs

Max.Marks-60

*Attempt 5 questions in all, selecting one question from each unit and Question 1 is compulsory. Each Question carries 12 marks.*

Q.1	Marks
(a) What is a mobile robot?	2
(b) Define autonomy in mobile robots.	2
(c) What is a holonomic robot?	2
(d) What is a LiDAR sensor used for?	2
(e) What is kinematics in mobile robots?	2
(f) What do you mean by PID control?	2

**UNIT-I**

Q.2(a) Explain the historical development and evolution of mobile robotics.	6
Q.2(b) Describe the applications of mobile robots across different sectors with neat sketch.	6
Q.3(a) Compare legged and wheeled locomotion in terms of stability and energy efficiency.	6
Q.3(b) Evaluate the importance to kinematic models and constraints in mobile navigation.	6

**UNIT-II**

Q.4(a) Analyze the characteristics of touch sensors and proximity sensors in terms of resolution, response time and sensitivity.	6
Q.4(b) Elaborate the construction and working principle of encoders.	6
Q.5(a) Compare between stepper motor and servomotor	6
Q.5(b) Evaluate the use of brushed DC motors and brushless DC motors in mobile robot.	6

**UNIT-III**

Q.6(a) Design forward kinematic equations for 2 link planer robot arm.	6
Q.6(b) Assess the importance of the Jacobian matrix in robotic motion.	6
Q.7(a) Develop a dynamic model of a three-joint robotic manipulator using the Lagrange–Euler method.	6
Q.7(b) Compare point-to-point trajectory planning and continuous trajectory planning for robotic manipulators.	6

#### UNIT-IV

- |        |  |   |
|--------|--|---|
| Q.8(a) | Explain the concept of feedback control in second-order linear systems and describe its relevance to robotic manipulators                            | 6 |
| Q.8(b) | Compare trajectory control and motion-planning schemes in robots.  | 6 |
| Q.9(a) | Illustrate how frame grabbing and masking techniques are used in a robot vision system for object recognition  | 6 |
| Q.9(b) | Apply the concept of pre-processing and edge detection in robot vision to outline the procedure for extracting object boundaries from an input image | 6 |

--- ---- ----