

Roll No. ....

Total Pages : 03

BT-4/M-23

44156

APPLIED AND COMPUTATIONAL  
MATHEMATICS

BS-207A

Time : Three Hours]

[Maximum Marks : 75

**Note :** Attempt *Five* questions in all, selecting at least *one* question from each Section. All questions carry equal marks.

## Section A

1. (a) Find the solution to the Bernoulli equation :

$$\frac{dy}{dx} + \frac{y}{x} = x^2 y^2$$

- (b) Solve the ordinary differential equation :

$$\frac{d^2 y}{dx^2} - 2 \frac{dy}{dx} + 4y = \sin 2x$$

2. (a) Solve the partial differential equation

$$(p^2 + q^2)y - qz = 0 \text{ using Charpits' method.}$$

- (b) Solve the partial differential equation :

$$2 \frac{\partial^2 z}{\partial x^2} - 7 \frac{\partial^2 z}{\partial x \partial y} + 6 \frac{\partial^2 z}{\partial y^2} = xy$$

## Section B

3. (a) Evaluate  $\int_0^2 \int_0^{\sqrt{2x-x^2}} \frac{x \, dy \, dx}{\sqrt{x^2 + y^2}}$  by changing to polar form.
- (b) Evaluate the integral  $\iiint (x^2 + y^2 + z^2) \, dx \, dy \, dz$  throughout the volume of the sphere  $x^2 + y^2 + z^2 = 9$ .
4. (a) Find the angle between the surfaces  $x^2 + y^2 + z^2 = 9$  and  $z = x^2 + y^2 - 3$  at the point  $(1, 2, 3)$ .
- (b) Find the directional derivative of the function  $xy + yz + zx$  at the point  $(1, -2, 2)$  in the direction of the vector  $\hat{i} + \hat{j} + \hat{k}$ .

## Section C

5. (a) Find the Laplace transform of the function  $(t+1)^2 e^t$ .
- (b) Find the Laplace transform of the function  $e^{-2t} \cos 5t$ .
6. (a) Find the inverse Laplace transform of  $\frac{1}{(s^2 + 1)(s^2 + 4)}$  using convolution

- (b) Using Laplace transformation solve the initial value problem :

$$y'' - 4y' + 4y = 16\sin 2t, \quad y(0) = 0, \quad y'(0) = 1$$

### Section D

7. (a) Find the roots of the equation  $x - e^{-x} = 0$ , correct to three decimal places using Newton-Raphson method.
- (b) Dividing the range into 10 equal parts, find the approximate value of  $\int_0^1 \frac{1}{1+x} dx$  using Trapezoidal Rule.
8. (a) Using Runge-Kutta method of fourth order, find the numerical solution at  $x = 0.8$  for the initial value problem  $\frac{dy}{dx} = \sqrt{x+y}$ ,  $y(0.4) = 0.41$ , with the step length  $h = 0.2$ .
- (b) Using Lagrange interpolation formula, find the unique polynomial  $P(x)$  of degree 2 or less such that :

$$P(1) = 1, P(3) = 27, P(4) = 64$$

Roll No. ....

Total Pages : 03

**BT-4/M-23**

**44157**

**DIGITAL COMMUNICATION**

**EC-202A**

Time : Three Hours]

[Maximum Marks : 75

**Note :** Attempt *Five* questions in all, selecting at least *one* question from each Unit.

**Unit I**

1. (a) State and prove sampling theorem for baseband signals. Determine the Nyquist rate and Nyquist interval for  
(i)  $g(t) = \sin (200 t)$  (ii)  $g(t) = \sin^2 (200 t)$   
(iii)  $g(t) = \sin (200t) + \sin^2(200 t)$ . 7
- (b) Describe in detail process of PCM. Describe various steps in detail. Find the signal to quantization noise ratio when signal  $s(t) = 3 \cos (1000\pi t)$  is quantized using 10 bit PCM. 8
2. (a) Define PAM. Derive an expression for PAM waveform. 5
- (b) Describe algorithm of Delta Modulation. Illustrate two different types of quantization errors that may occur in delta modulation technique. A signal is given by  $e(t) = 20 \cos (1000\pi t) + 15 \cos (1500\pi t)$ .

The signal is quantized using delta modulation. Select an appropriate sampling rate and step size to transmit the signal avoiding slope overload. 10

### Unit II

3. (a) What is ISI ? Derive an expression for ISI. Discuss ideal Nyquist channel model for zero ISI. 7
- (b) Explain the need of matched filter at receiver. Find the impulse response of an optimum filter. 8
4. Draw block diagram of adaptive equalizer. Mention its working. Also give Least Mean Square algorithm and describe how it is used in adaptive equalizer ? 15

### Unit III

5. (a) Describe the process of coherent detection of signals in noisy environment. Explain how the probability of error is minimized in decision making process with the help of Maximum likelihood decoding. 7
- (b) Describe Gram-Schmidt orthogonalization procedure. 8
6. Discuss BPSK and QAM modulation techniques in detail. Also draw diagram for their transmitter and receiver. 15

### Unit IV

7. (a) Mention need of synchronization. Discuss two modes of synchronization that may be required at receiver and transmitter. 8

- (b) Mention algorithm of Maximum Likelihood Sequence estimation. Draw block diagram of MLSE equalizer along with its working. 7
8. Write a short note on need of trade-off among various parameters used to choose adequate digital modulation technique. 15

Roll No. ....

Total Pages : 03

BT-4/M-23

44158

ANALOG CIRCUITS

EC-206A

Time : Three Hours]

[Maximum Marks : 75

**Note :** Attempt *Five* questions in all, selecting at least *one* question from each Section. Each question carries 15 marks.

**Section I**

1. (a) In a single stage CB amplifier circuit.  $R_E = 20 \text{ K}$ .  
 $R_c = 10 \text{ K}$ ,  $V_{EE} = -20 \text{ V}$ ,  $V_{cc} = 20 \text{ V}$ .  $R_L = 10 \text{ K}$ .  
Find out  $R_i$ ,  $R_o$ ,  $A_i$ ,  $A_v$  and power gain in dB.  
10
- (b) Draw the circuit of two stage R-C coupled transistor amplifier and explain the working of it. 5
2. (a) Derive expression for  $A_v$  and  $R_o$  for common gate amplifier. 8
- (b) Show that total gain is equal to the product of gains of individual stages in a multi-stage amplifier.

7

## Section II

3. (a) Show that the transformer coupled class A amplifier, maximum efficiency is 50%. **8**
- (b) Explain the frequency response of amplifier in different regions. **7**
4. An amplifier circuit has a gain of 60 dB and an output impedance  $Z_o = 10 \text{ K}$ . It is required to modify its output impedance to  $500 \text{ } \Omega$  by applying negative feedback. Calculate the value of the feedback factor. Also find the percentage change in the overall gain, for 10% change in the gain of the internal amplifiers. Also state the advantages and disadvantages of negative amplifier in detail. **15**

## Section III

5. (a) In a Colpitt's oscillator, the values of the inductors and capacitors in the tank circuit are  $L = 40 \text{ mH}$ ,  $C_1 = 100 \text{ pF}$ ,  $C_2 = 500 \text{ pF}$ .
- (i) Find the frequency of oscillation.
- (ii) If the output voltage is 10 V, find the feedback voltage.
- (iii) Find the minimum gain, if the frequency is changed by changing 'L' alone.
- (iv) Find the value of  $c_1$  for a gain of 10.
- (v) Also find the new frequency of oscillation. **10**

- (b) Explain the principle of operation of the Wein Bridge Oscillator. 5
- 6. (a) Derive conditions for sustained oscillations in a RC Phase shift oscillator. 7
- (b) Explain the working and applications of 555 timer monostable multivibrator. 8

#### Section IV

- 7. (a) Explain the working of Schmitt trigger circuit using op-amp and also sketch the hysteresis plot. 7
- (b) Calculate the amplification factor for AC signal input in dual input balanced output differential amplifier. 8
- 8. (a) Explain and derive the current expression of current mirror circuit diagram. 5
- (b) Define the following : 10
  - (i) CMRR
  - (ii) Gain
  - (iii) Gain-bandwidth product
  - (iv) Slew rate
  - (v) Input impedance for an op-amp.

Roll No. ....

Total Pages : 03

BT-4/M-23

44159

MICROPROCESSORS AND  
MICROCONTROLLERS  
EC-210A

Time : Three Hours]

[Maximum Marks : 75

Note : Attempt *Five* questions in all, selecting at least *one* question from each Unit. All questions carry equal marks.

**Unit I**

1. (a) Draw the pin diagram of 8086 and explain the function of each pin. 8
- (b) Draw the block diagram of 8085 and explain the function of various internal units in detail. 7
2. Draw and discuss the typical minimum mode 8086 system with read and write cycle timing diagram. 15

**Unit II**

3. (a) Design architectural diagram of 8051 and explain its core and peripherals features. 10
- (b) Explain the internal RAM organization of 8051 with suitable diagram. 5

4. Describe the need and features of UART. Also, explain its various operating modes and associated registers. 15

### Unit III

5. (a) Assume that XTAL = 11.0592 MHz. Write an assembly program to generate a square wave of 2 kHz frequency on pin P1.5. 10
- (b) Assume that bit P2.3 is an input and represents the condition of an oven. Write an assembly program for if it goes high, it means that the oven is hot. Monitor the bit continuously. Whenever it goes high, send a high-to-low pulse to port P1.5, to turn on a buzzer. 5
6. (a) Write an assembly program to transfer the message "WELCOME" serially at 9600 baud, 8-bit data, and 1 stop bit. Do this continuously. 10
- (b) Find the time delay generated by the following instruction. Assume crystal frequency is 12 MHz.

MOV R0, #20

THERE: MOV R1, #250

HERE: DJNZ R1, HERE

DJNZ R0, THERE 5

## Unit IV

7. Interface 32KB of EPROM and 64KB of RAM starting at 00000H to 8086. 15
8. Explain the operation, programming and interfacing diagram of DAC with 8051. 15

Roll No. ....

Total Pages : 02

BT-4/M-23

44160

ELECTROMAGNETIC FIELD THEORY

EC-214A

Time : Three Hours]

[Maximum Marks : 75

Note : Attempt *Five* questions in all, selecting at least *one* question from each Unit. All questions carry equal marks.

Unit I

1. For what purpose we are using method of images ?  
Explain application of method of images with an example. 15
2. State and explain the Gauss's law. Explain the applications of Gauss's law with example. 15

Unit II

3. State and prove Maxwell's equations in differential and integral form. Give their physical interpretation. 15
4. Explain boundary conditions for electric field. 15

Unit III

5. Explain reflection and refraction of uniform plane wave. 15

6. Derive the wave equations from the Maxwell's equations for free space. 15

#### Unit IV

7. Explain the model of Transmission line. Also explain transmission line equations. 15
8. What do you understand by TE, TM and TEM mode ? Also write short note on : Cut-off and Guided Wavelength in waveguide. 15

Roll No. ....

Total Pages : 03

BT-4/M-23

44161

BASIC OF ANALOG COMMUNICATION

EEN-202A/ES-208A

Time : Three Hours]

[Maximum Marks : 75

Note : Attempt *Five* questions in all, selecting at least *one* question from each Unit. All questions carry equal marks.

Unit I

1. (a) Differentiate between Wired and Wireless media for communication. 8
- (b) Give the classification of signals in communication system. 7
2. (a) Differentiate between External and Internal noises. 8
- (b) Define signal-to-noise ratio and noise figure of a receiver. 7

Unit II

3. (a) Describe the basic constituents of communication system. 7

- (b) Find an expression for the instantaneous voltage of an Amplitude modulated signal. Draw the waveforms for Amplitude Modulated signal. Also describe the power relations involved in AM. 8
4. (a) Explain the square law modulation method for conventional AM generation. 8
- (b) Explain the working of Linear diode detector for detection of AM signal. 7

### Unit III

5. (a) Explain the spectrum of a frequency modulated signal and compare it with that of amplitude modulated signal. 8
- (b) Write a short note on Pre-emphasis and De-emphasis. 7
6. (a) Explain the working of Foster-Seeley discriminator with a phasor diagram. 8
- (b) Explain the concept of Noise Triangle. 7

### Unit IV

7. (a) Explain with the help of a block diagram a simple FM transmitter using Reactance Modulator. 8

- (b) Explain the concept of Image Frequency and its rejection. 7
8. (a) Draw and explain the block diagram of superheterodyne receiver. 8
- (b) Explain the working of SSB receiver with the help of a block diagram. 7

Roll No. ....

Total Pages : 2

**BT-6/M-23**  
**ORGANISATIONAL BEHAVIOUR**  
**Paper-HM-901A**

**46186**

Time : Three Hours]

[Maximum Marks : 75

**Note :** Attempt *five* questions in all, by selecting at least *one* question from each unit.

**UNIT-I**

1. With the greater use of technology and automation in today's organisation which skills are more important to be possessed by managers to effectively deal with individuals, group/organisation behaviour issues at work. What roles modern day manager has to play to manage the behavioural issues?
2. Figure out certain significant challenges in smooth application of Organisational Behaviour principles in modern day technology enabled. Use examples.

**UNIT-II**

3. Which principles and theories of motivation works best for changing employee dynamics at modern workplaces. Justify your viewpoint.
4. Figure out the most effective strategies and approaches for managing stress and associated issues among today's workforce. Use relevant examples.

46186/600/KD/1104

144 [P.T.O.  
20/6

### UNIT-III

5. Keeping in view the rising uncertainties in modern day business environment, which theories and styles of leadership are most relevant as well as effective and Why? Give appropriate justifications.
6. Define Group Cohesiveness. What are its Symptoms? Discuss the impact of high degree as well as low degree of cohesiveness on group performance.

### UNIT-IV

7. Examine various types of Organisational Change. Identify the prominent reasons for resistance towards change and suggest appropriate strategies for overcoming resistance to change.
  8. What is Workforce Diversity? Is it good or bad for an organisation in modern times? Discuss the certain methods or approaches or measures through which workforce diversity can be managed in organisations.
-

Time : Three Hours]

[Maximum Marks : 75

Note : Attempt *five* questions by selecting atleast *one* question from each Unit.

UNIT-I

1. (a) Find the overall transfer function by using Mason's gain formula for the signal graph shown below in Fig. 1?

7

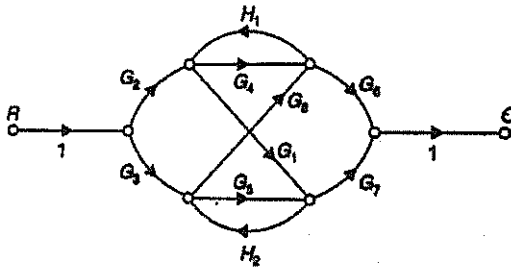

Fig. 1.

- (b) Determine the system equations for the system as shown in Fig. 2 below.

8

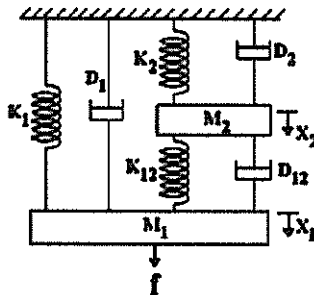

Fig. 2.

2. (a) Obtain the transfer of the system given below in Fig. 3 using block diagram reduction method.

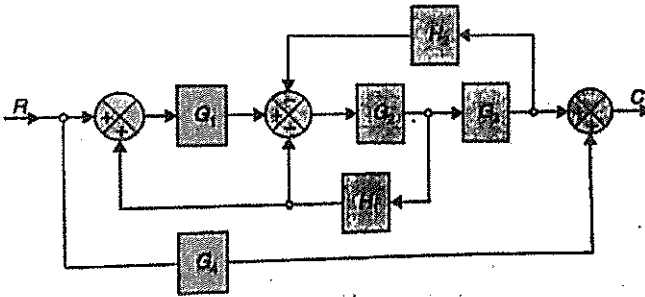

Fig. 3.

- (b) Determine the sensitivity of the closed loop transfer function for the system shown below in Fig. 4 at  $\omega = 1$  rad/sec w.r.t. (i) forward path transfer function (ii) feedback path transfer function.

### UNIT-II

3. (a) A unity feedback control system has  $G(s) = 1/s(s + 2)$ . The input to the system is given by  $r(t) = 2 + 3t + 2t^3$ . Determine the generalized error coefficients and steady state error.

- (i) A unity negative feedback system has an open loop transfer function as

$$G(s) = \frac{K(S + 1)(S + 2)}{(S + 0.1)(S - 1)}$$

Find range of 'K' for the closed loop system to be stable using Routh criterion.

4. Consider a unity feedback control system with an open loop transfer function of

$$G(s) = \frac{K}{(s)(s+4)(s^2+4s+20)}$$

- (i) Draw the root locus of the system with gain 'K' as a variable.
- (ii) Determine the asymptotes, centroid, breakaway point and the gain at which root locus crosses imaginary axis.
- (iii) Also find the value of gain 'K' for which the closed loop system is critically damped. (4+4=8)

### UNIT-III

5. Sketch the BODE plot for the following transfer function

$$G(s) = \frac{1000}{(1+0.1s)(1+0.001s)}$$

Determine the

- (i) Gain Crossover Frequency.
  - (ii) Phase Crossover Frequency.
  - (iii) Phase Margin.
  - (iv) Gain Margin.
  - (v) Stability of the System. 15
6. Sketch the Nyquist plot and determine the stability of a unity feedback control system whose open loop transfer function is as follows :

$$G(s) = \frac{K}{(1+ST_1)(1+ST_2)}$$

## UNIT-IV

7. (a) Obtain the state model for the given transfer function

$$G(s) = \frac{Y(s)}{U(s)} = \frac{K(C_2 S + C_1)}{(S^3 + a_3 S^2 + a_2 S + a_1)}$$

- (b) A system is characterized by the following transfer function :

$$= \frac{Y(s)}{U(s)} = \frac{2}{S^3 + 6s^2 + 11s + 6}$$

Find the state and output equation in matrix form and also test the controllability and observability of the system. 7

8. The open loop transfer function of an uncompensated system is

$$G(s) = \frac{5}{S(S+2)}$$

Design a lead compensator for the system so that the static velocity error constant  $K_v \geq 20 \text{ sec}^{-1}$ , the phase margin is at least  $55^\circ$  and the gain margin is at least 12 dB? 15

---

Roll No. ....

Total Pages : 3

BT-6/M-23

**46258**

VERILOG HDL

Paper-EC-306A

Time : Three Hours]

[Maximum Marks : 75

**Note :** Attempt *five* questions in all, selecting at least *one* question from each unit.

### UNIT-I

1. Draw and discuss ASIC design flow. 15
2. (a) Differentiate between simulation and synthesis. 8  
(b) List and explain various identifiers. 7

### UNIT-II

3. (a) Using Gate level modelling, write and explain Verilog program for JK flip-flop. 8  
(b) Differentiate between initial and always construct with examples. 7
4. (a) Using Gate level modelling, write and explain Verilog program of 4 : 1 MUX. 8  
(b) Explain blocking and non-blocking assignments. 7

46258/250/KD/976

15 [P.T.O.  
15/6

### UNIT-III

5. (a) Describe continuous assignment structures with examples. 8
- (b) Write and explain Verilog program for the CMOS inverter. 7

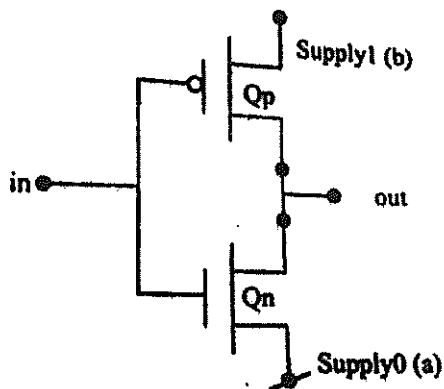

6. (a) List and explain various types of operators used in Verilog HDL. 8
- (b) Describe bidirectional gates with illustrations. 7

### UNIT-IV

7. (a) Explain and differentiate Moore and Mealy machines with examples. 8
- (b) Write note on following :
- (i) Compiler Directives. 3.5
- (ii) Hierarchical Access. 3.5

8. (a) Explain User-Defined Primitives (UDP) with examples. 8
- (b) Write note on following :
- (i) System Task and Functions. 3.5
  - (ii) File-based Task and Functions. 3.5
-

BT-6/M-23

46259

## ANTENNAS AND PROPAGATION

Paper-ECP-6A

Time : Three Hours]

[Maximum Marks : 75

**Note :** Attempt *five* questions by selecting at least *one* question from each unit.

## UNIT-I

1. (a) Explain the radiation mechanism of antenna.  
(b) Explain the various terms used in antenna :
  - (i) Directive Gain.
  - (ii) Power Gain.
  - (iii) Directivity.
  - (iv) Beam width. (15)
2. Explain the current distribution on Hertzian dipole antenna, Short dipole antenna and Half wave dipole antenna. Also write short note on Monopole antenna. (15)

## UNIT-II

3. Find the expression of radiated fields Due to N element antenna array. Also find the condition for maximum radiation for N element antenna array. (15)
4. Write short note on Chebyshev array. (15)

### UNIT-III

5. With constructional details explain working of Frequency independent Log spiral antenna. (15)
6. Explain Advantages and basic Configurations of Patch antenna. Also explain Different feeding techniques of Patch antenna. (15)

### UNIT-IV

7. Write short notes on :
    - (a) Critical frequency
    - (b) Multi hop propagation.
    - (c) Skip distance
    - (d) Duct propagation. (15)
  8. Explain various techniques of radio wave propagation. (15)
-

Roll No. ....

Total Pages : 3

BT-6/M-23

46264

MULTIMEDIA COMMUNICATIONS

Paper-ECO-6A

Time : Three Hours]

[Maximum Marks : 75

**Note :** There are eight questions in this Paper. Each question carries 15 marks. Attempt any *five* questions in all by selecting at least *one* question from each unit.

### UNIT-I

1. (a) What is multimedia communication? Explain data networks and its packet mode of operation with the help of diagram. (8)
- (b) Differentiate between MOD and NMOD with the help of suitable diagrams. (7)
  
2. Explain the following terms in multimedia communication :
  - (i) Audio synthesizer.
  - (ii) Digitization of an analog signal. (7.5×2=15)

### UNIT-II

3. (a) The probabilities of the characters a to d are  $a = 0.25$ ,  $b = 0.1$ ,  $c = 0.15$  and  $d = 0.50$ . Derive the Huffman coding tree and also derive the code words of characters A to D during transmission. (8)

- (b) Explain with the help of proper examples :
- (i) Run Length Encoding
  - (ii) Transform Encoding. (7)
4. (a) Differentiate between GIF and TIFF encoding in image compression. (5)
- (b) With the help of block diagram, explain the steps of Quantization and Entropy encoding in JPEG encoder. (10)

### UNIT-III

5. (a) How the limitations of DPCM are overcome by DPCM? Explain with the help of block diagrams. (8)
- (b) What is Linear Predictive coding? What are its advantages? (7)
6. (a) Differentiate between motion estimation and motion compensation in video frames. (5)
- (b) Explain H.263 video compression standard in detail along with its error tracking and controlling process. (10)

### UNIT-IV

7. Write a detailed note on :
- (i) Pack Architecture.
  - (ii) Multimedia synchronization.
8. (a) What is Internet Telephony? Explain various protocols associated with it. (8)

- (b) With the help of block diagram, explain the concept of content based image retrieval systems. Explain any *two* of its applications. (7)
-

Roll No. ....

Total Pages : 3

BT-6/M-23

46266

TRANSDUCERS AND THEIR APPLICATIONS

Paper-ECO-8A

Time : Three Hours]

[Maximum Marks : 75

**Note :** Attempt *five* questions in all, selecting at least *one* question from each unit.

UNIT-I

1. (a) Differentiate between primary and secondary transducers. (7)
- (b) Explain working of Wheatstone bridge as resistive transducer. (8)
2. (a) Elaborate and explain Hall effect. Explain any *two* applications of sensors based on Hall effect. (5)
- (b) What are photoelectric transducers? Explain how photoconductive cells may be used to measure radiance or illumination of light? Also describe their characteristics, advantages and disadvantages. (10)

UNIT-II

3. Explain how a Bourdon tube can be used to measure pressure? Mention the characteristics, merits and demerits of Bourdon tube. The output of LVDT is connected to a 5 V voltmeter through an amplifier whose amplification factor is 250. An output of 2 mV appears across the terminals of LVDT

46266/200/KD/1211

214 [P.T.O.  
28/6

when core moves through a distance of 0.5 mm. Calculate the sensitivity of LVDT and that of whole setup. The millivoltmeter scale has 100 divisions. The scale can be read to 1/5 of a division. Calculate resolution of the instrument in mm. (15)

4. What are thermistors? Explain working of *two* different types of thermistors. Derive relationship between temperature and resistance of thermistor. Draw and explain characteristics of thermistors. A thermistor has a resistance of 3980 ohm at the ice point and 794 ohm at 50°C. The resistance temperature relationship is given by  $R_t = a R_o e^{b/T}$ . Calculate constants  $a$  and  $b$ . Calculate the range of resistance to be measured in case the temperature varies from 40 to 100°C. (15)

### UNIT-III

5. (a) Explain how LVDT may be used as inductive transducer? Give relationship between output voltage and displacement. Also draw graph for that. A steel cantilever is 0.25 m long, 20 mm wide and 4 mm thick. (i) Calculate the value of deflection at the free end for the cantilever when a force of 25 N is applied at this end. The modulus of elasticity for steel is 200 GN/m<sup>2</sup>. An LVDT with a sensitivity of 0.5 V/mm is used. The voltage is read on a 10 V voltmeter having 100 divisions. Two-tenths of a division can be read with certainty. (ii) Calculate the minimum and maximum value of force that can be measured with this arrangement. (10)

- (b) Explain working principle of capacitive transducer. (5)
6. Discuss working of :
- (i) AC tachometer generator.
  - (ii) Toothed rotor tachometer generator. (15)

#### UNIT-IV

7. Discuss working principle of resistance Strain-gauge used for measurement of force. Support the justification with necessary expressions and derivation. (15)
8. Describe working of dynamometer to measure torque. For a certain dynamometer ammeter the mutual inductance  $M$  varies with deflection  $\theta$  (expressed in degrees) as  $M = -6 \cos (\theta+30^\circ)$  mH. Find the deflecting torque produced by a direct current of 50 mA corresponding to a deflection of  $60^\circ$ . (15)
-

Roll No. ....

Total Pages : 2

BT-8/M-23

48250

## SATELLITE COMMUNICATION

Paper-OE-CS-404A

Time Allowed : 3 Hours]

[Maximum Marks : 75

**Note** : Attempt **five** questions in all, selecting at least **one** question from each Unit. All questions carry equal marks.

### UNIT-I

1. Discuss in detail the Kepler's 1st, 2nd and 3rd laws of Orbital Mechanics. Draw diagrams where necessary. 15
2. What are Look Angles ? Derive the equation for the generation of Elevation angle. Also, Discuss about subsatellite point. 15

### UNIT-II

3. Discuss in detail TTC&M system with the help of a block diagram. 15
4. (a) What is Attitude Control ? Why it is used ?  
(b) What are Transponders ? Discuss the working of Bent-pipe and Double Conversion transponder. 15

48250/K/659/300

P. T. O.

### UNIT-III

5. (a) Derive and explain the basic transmission theory using the link equation.  
(b) Differentiate between Uplink and Downlink attenuation in Rain. 15
6. Derive the relation between system noise temperature and G/T ratio. Also, discuss the types of RF to IF conversion systems used in this using suitable diagrams. 15

### UNIT-IV

7. Write short notes on the following :  
(a) CDMA systems  
(b) DBS-TV. 15
8. What are multiple access techniques ? Compare FDMA TDMA and DAMA techniques with necessary diagrams. 15

Roll No. ....

Total Pages : 2

BT-8/M-23

48310

## INTERNET OF THINGS

Paper-ECP-22A / OEC-BT-424A

Time Allowed : 3 Hours]

[Maximum Marks : 75

**Note** : Attempt **five** questions in all, selecting at least **one** question from each Unit. All questions carry equal marks.

### UNIT-I

1. (a) Define IoT. Draw the Logical design for architecture of the reference model of IoT. Mention working of each layer. 8
- (b) Describe features of IPv4 and IPv6 protocols. 7
2. (a) What is M2M ? Draw and explain the architecture of M2M. How does it differ from IoT? 7
- (b) Draw diagram for SDN architecture. Describe it in detail. 8

### UNIT-II

3. (a) Explain use of IoT system for weather monitoring. 8
- (b) What are Sensors ? Classify sensors. 7

48310/K/991/100

P. T. O.

4. Draw and explain block diagram showing architecture of Raspberry pi. Mention various interfaces present over it. Why is pi called CPU on a chip ? Write down a programme to interface an analog temperature sensor with Raspberrypi. 15

### UNIT-III

5. Explain the operations of (a) MQTT protocol, (b) PEGASIS protocol. 15
6. (a) Discuss concept of Cloud computing. Explain how Fog computing overcomes the limitations of Cloud computing. 8
- (b) Mention different Security issues faced while designing IoT system. 7

### UNIT-IV

7. How is Python language helpful in implementing IoT concept ? Discuss different types of libraries available in Python language that are used in developing IoT projects. 15
8. Develop an IoT system architecture for smart transportation via connected cars. Also brief underlying technologies that supports the application. Describe different types of services that may be provided by Smart transportation system using IoT. 15

Roll No. ....

Total Pages : 3

BT-8/M-23

48316

## SOFT COMPUTING

Paper-ECO-13A

Time Allowed : 3 Hours]

[Maximum Marks : 75

**Note** : Attempt **five** questions in all, selecting at least **one** question from each Unit. All questions carry equal marks.

### UNIT-I

1. (a) Explain the use of activation functions in Neural Networks. Describe the activation functions that can be used in Neural Networks. 5
- (b) Differentiate between Neural Networks and Artificial Intelligence. 5
- (c) List the various types of Crossover and Mutation techniques in GA. 5
2. (a) Define the terms (i) Fuzzy sets, (ii) Crisp sets, (iii) Membership function. 8
- (b) Explain major phases involved in ART classification process. 7

### UNIT-II

3. (a) Define BAM. Explain BAM operation using diagram. 10

48316/K/838/200

P. T. O.

- (b) Describe how association encoding and decoding will be done in BAM. 5
4. (a) Explain the working principle of a Perceptron. Write the training algorithm of a Single layer discrete-perceptron network. 7
- (b) Differentiate between Supervised and Unsupervised Training of Artificial Neural Network. 8

### UNIT-III

5. (a) Discuss the methods of Aggregation of Fuzzy rules. 5
- (b) With suitable block diagram, explain the working principle of Fuzzy Inference System. 5
- (c) Explain the different types of Membership function used in Fuzzification process. 5
6. (a) The discretized membership functions for a transistor and a resistor are given below : 8

$$\mu_T = \{0/0 + 0.2/1 + 0.7/2 + 0.8/3 + 0.9/4 + 1/5\}$$

$$\mu_R = \{0/0 + 0.1/1 + 0.3/2 + 0.2/3 + 0.4/4 + 0.5/5\}$$

Find the following :

- (i) Algebraic sum (ii) Algebraic product,  
 (iii) Bounded sum, (iv) Bounded difference.
- (b) Discuss about the four modes of Fuzzy reasoning. 7

## UNIT-IV

7. (a) A recurrent Network has 3 source nodes, 2 hidden Neurons, and 4 output Neurons. Construct an Architectural graph that describes such a Network. 7
- (b) In detail discuss about hebbian learning rule, perceptron learning rule. 8
8. (a) Implement Optimization of Traveling Salesman Problem using Genetic algorithm approach. 8
- (b) Design a Fuzzy Logic controller to simulate a temperature control system for a room. 7

Roll No. ....

Total Pages : 2

BT-8/M-23

48317

## NEURAL NETWORKS AND FUZZY LOGIC

Paper-ECO-14A

Time Allowed : 3 Hours]

[Maximum Marks : 75

**Note** : Attempt five questions in all, selecting at least one question from each Unit. All questions carry equal marks.

### UNIT-I

1. Draw the block diagram of a basic Neural Network. Explain the evaluation of Neural Network models and important technologies. 15
2. What is Fuzzy Logic ? With the help of examples explain crisp sets, fuzzy sets, crisp relations and Fuzzy relations. 15

### UNIT-II

3. Differentiate between Auto-associative and Hetero-associative memory networks. Explain each in detail. 15
4. What do you understand by Unsupervised Learning Networks ? Describe the Kohonen self organizing feature maps and ART Network. 15

48317/K/899/50

P. T. O.

### UNIT-III

5. With the help of suitable examples explain fuzzification and defuzzification in detail. 15
6. What do you mean by Fuzzy Inference systems ? Describe Fuzzy decision systems. 15

### UNIT-IV

7. What are Neuro-fuzzy hybrid systems ? Describe simplified fuzzy ARTMAP in detail. 15
8. Explain the Soft computing based Hybrid Fuzzy controllers. 15

Roll No. ....

Total Pages : 2

BT-8/M-23

48319

## MIXED SIGNAL DESIGN

Paper-ECO-16A

Time Allowed : 3 Hours]

[Maximum Marks : 75

**Note** : Attempt **five** questions in all, selecting at least **one** question from each Unit. All questions carry equal marks.

### UNIT-I

1. (a) Derive an Integrator using Switched Capacitor Circuit. 7
- (b) Draw the basic circuit of a switched capacitor, its equivalent circuit, explain its operation and derive its equivalent resistor value. 8
2. (a) Quantitatively explain charge injection and clock-feedthrough in MOS switch. 7
- (b) Draw the circuit diagram and explain the working of a Switched Capacitor (SC) integrator. Quantitatively explain the working of a supply independent reference circuit. 8

### UNIT-II

3. (a) Draw the block diagram of a charge pump PLL and explain the functions of each block. 8
- (b) Explain the Jitter in PLLs and delay locked loops. 7

48319/840/150

P. T. O.

4. (a) With the help of necessary waveforms, explain about the non-ideal effects in PLLs. 7
- (b) With the help of a block diagram basic CMOS comparator design. Give the characterization of Computer. 8

### UNIT-III

5. (a) Draw the block diagram of a D-A converter in Signal Processing applications. Give the classification of a D-A converters. 8
- (b) Explain the Static and Dynamic characteristics of DAC. 7
6. (a) Draw the circuit diagram of a R-2R DAC and explain its operation. 8
- (b) Design a Thermometer Code charge redistribution D/A converter. 7

### UNIT-IV

7. (a) What is a Flash converter ? Design a 3-bit Flash ADC with quantization error centered about zero LSBs. 7
- (b) Mention all kinds of medium speed and high speed ADC and explain the operation of a multiple-bit pipeline ADC. 8
8. (a) Explain about deterministic approach and statistic approach of quantization noise in data converters. 7
- (b) Describe the working of successive approximation type A/D converter ? With neat diagram, explain the working of a sample and hold circuit. 8